

Portable Mercury Survey Meter- its built-in GPS broadens the applications in various fields

Thanks to its GPS function, you don't need to record the measurement points manually when measuring at various spots in the field, thus leading to smooth measurement. Compared with its previous model, the measuring range of the EMP-3 has doubled to $2,000 \mu\text{g}/\text{Nm}^3$ and its body has become more compact and lighter. With its splashed-proof seamless design and accompanying double-belt, the EMP-3 allows you to respond to a variety of measurement needs with greater peace of mind.

High sensitivity and wide range

In addition to its high-sensitivity ($0.1 \mu\text{g}/\text{Nm}^3$), the EMP-3 covers a wide range of concentrations as high as $2000 \mu\text{g}/\text{Nm}^3$

Mercury is toxic to human health and its vapor is colorless and odorless, making it difficult to sense its presence in the environment by human. Some of the health effects to exposure to mercury may cause include irritation to the eyes and skin; cough, chest pain, or difficulty breathing, headache and more. Prolong exposure effect may be more acute. The level of exposure depends upon the dose, duration, and work being done. Therefore, it is critical to be able to measure the Mercury level at-site, real-time with accuracy.

Nippon Instruments Corporation (NIC) Mercury Survey Meter, EMP-3, is a revolutionary, versatile field hand-held Mercury detector accurately measures toxic Mercury in ambient atmosphere in real-time. Such real-time response is highly-crucial so as to allow quick-decision making to evacuate or to equip with proper levels or types of PPEs (Personal Protective Equipment) accordingly to minimize for any exposure.

Wide range: $0 \sim 2000 \mu\text{g}/\text{Nm}^3$

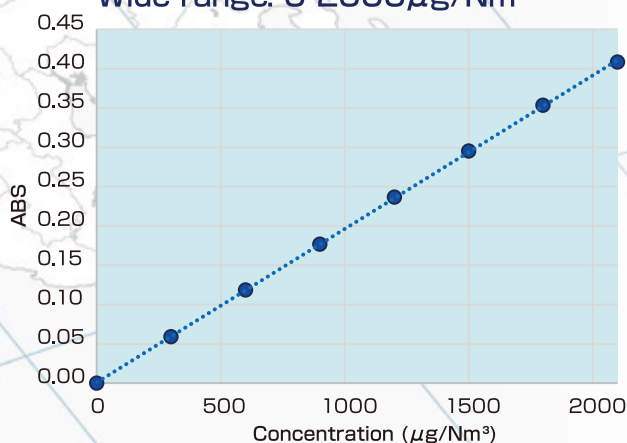

Low-concentration measurement

Sample: standard gas

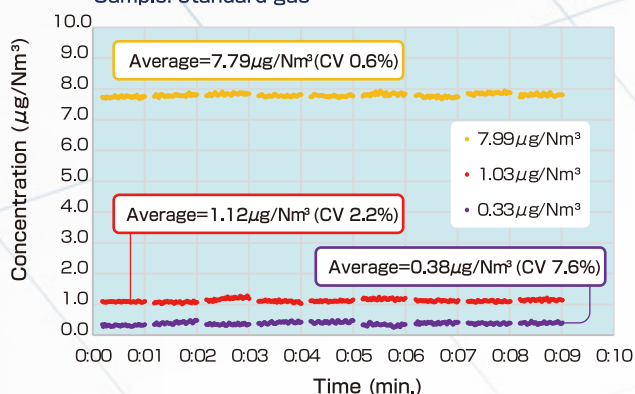

Clear view with tilting mechanism

The new LCD color touchscreen offers a significantly higher visibility than its previous model. Its tilting mechanism makes it easier to operate the unit when it is placed on a desk.

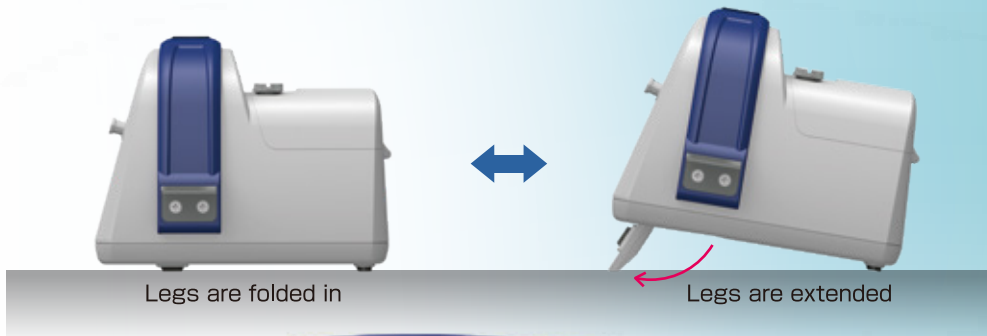

Unparalleled ease of operation through its high-resolution large LCD and user-friendly GUI

Comprehensive range of options

A wide variety of options are available for versatile applications such as high-concentration measurement and reducing vaporization measurement.

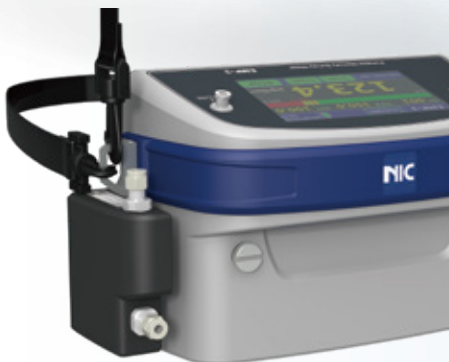

Hi-Lutor (option)
For high-concentration mercury measurement



AQUA kit (option)
For reducing vaporization mercury measurement

Schematic flow diagram

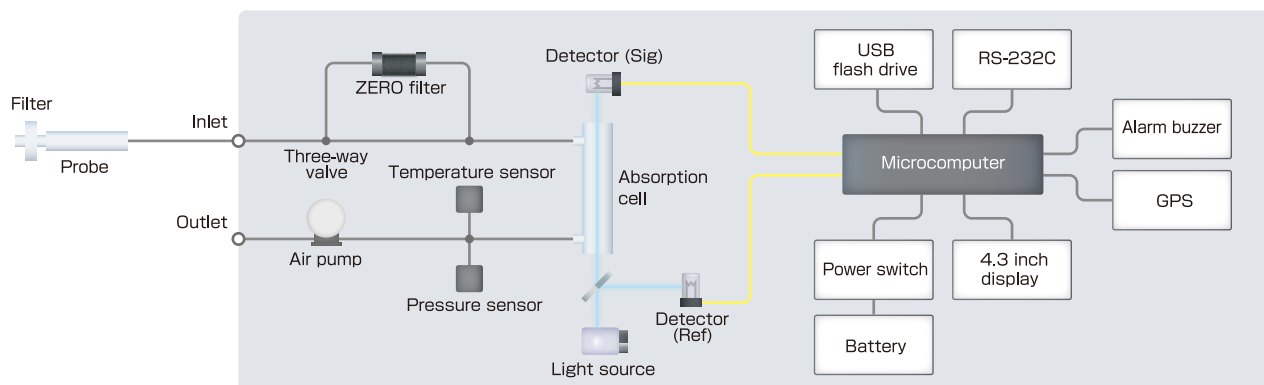

Specifications

Samples	Workplace, ambient air, petroleum gases, liquid samples (*1) *1 when used with AQUA option
Measuring principle	Non-dispersive double-beam cold vapor atomic absorption spectrometry
Light source	Low-pressure mercury discharge lamp
Detector	Semiconductor detector (with a 254 nm band-pass filter)
Detection limit	0.1 $\mu\text{g}/\text{Nm}^3$ (Normal)
Measuring range	0-2000 $\mu\text{g}/\text{Nm}^3$; 0-20000 $\mu\text{g}/\text{Nm}^3$ (*2) *2 when used with Hi-Lutor option
Flow rate during measurement	1 L/min
Precision	RSD 3% (2 $\mu\text{g}/\text{Nm}^3$ or higher) without any option
Zero correction	Automatic zero correction
Resolution	STATIC mode (Stationary mode) : 0.1 $\mu\text{g}/\text{Nm}^3$ (999.9) MOBILE mode (Portable mode) : 1 $\mu\text{g}/\text{Nm}^3$
Display	4.3-inch color LCD (480 x 272 pixels, 16.77 million colors)
Operation	Touchscreen
Onscreen data	Instantaneous value, average value, maximum value, trend graph(on a specified time scale), level gauge (linked with an alarm setting)
Data logging	Saved in CSV files or in the internal onboard 4GB memory (capacity up to 20,000 hours)
Data output	USB flash drive
Alarm method	Alarm buzzer and screen flashing (The alarm setpoint is configurable.)
Other functions	Temperature compensation, pressure compensation, GPS information recording
Power source	Dedicated nickel hydride battery (continuous operation : 5.5 hours at 25°C)
Operating conditions	Temperature : 0-45°C, humidity : 10-80%RH (No dew condensation)
Dimensions, weight	207W x 115D x 140H, 1.6kg (including the battery)
Standard accessories	Probe, probe filter (x1), battery (x1), battery charger, shoulder/waist belt, USB flash drive

Spare parts/Consumables

Spare battery, Zero filter, probe filter

Options

Carrying case

AQUA kit

-- for reducing vaporization measurement (including software) (*1)

Hi-Lutor

-- for high concentration measurement (including software) (*2)

Long probe (extendable from approx. 250 to 800 mm)

CK-1 -- Calibration kit

Color options



These specifications are subject to change without prior notice.



Headquarters & Technical Centre
: 110 Nishikujō Gawarajōchō, Minami Ward, Kyoto, 601-8424, Japan
TEL : +81 75-748-6200 FAX : +81 75-748-6208
EMAIL : info-nic@rigaku.co.jp URL : www.hg-nic.com
ISO 9001:2015 & ISO 14001:2015 Accredited

Singapore office
: 61 Bukit Batok Crescent, #04-04A, Singapore 658078
TEL : +65-6873-7068 FAX : +65-6873-6372

Identify the right mercury analyzer for you
<https://www.hg-nic.com>



Distributors