

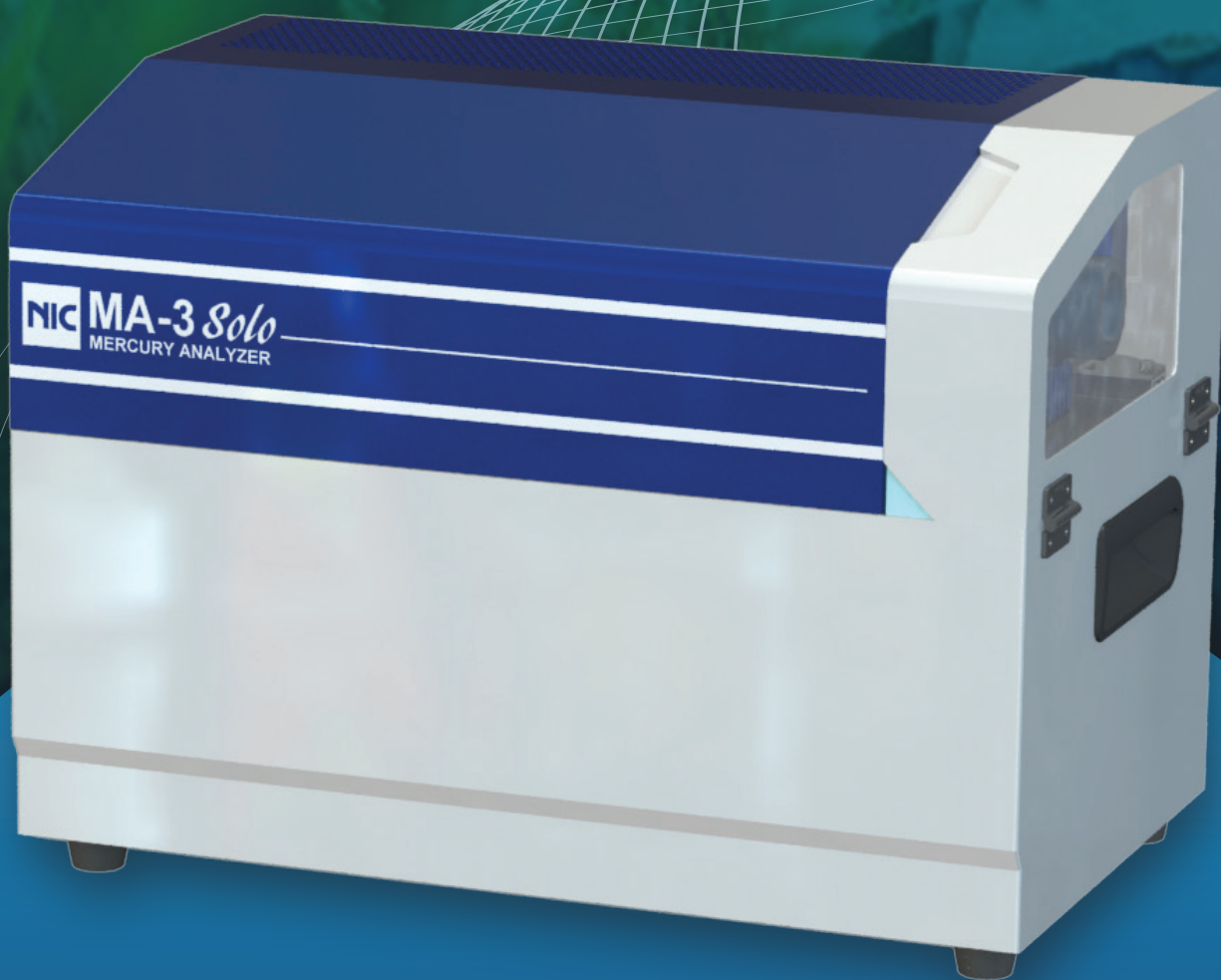

A Rigaku  
Company

**NIPPON  
INSTRUMENTS  
CORPORATION**



# MA-3 Solo

Affordable, High Performance Direct Mercury Analysis

USEPA 7473

ASTM D 7623-10

JIS K0102

ASTM D 6722-01

UOP 1009-15

UOP 938-20

# Affordable and Efficient Direct Mercury Analysis by MA-3 Solo

As regulations become stricter and compliance requirements more demanding, the need for accurate yet economical mercury analysis has been growing steadily. In response to this, Nippon Instruments Corporation (NIC) introduced the 2nd generation of MA-3 Solo Direct Thermal Decomposition Mercury Analyzer.

MA-3 Solo Direct Mercury Analyzer addresses this by utilizing technique of direct thermal decomposition, **eliminating the need for complex sample preparation** while ensuring reliable performance.

By streamlining features from our high-end models of MA-3000 —such as removing the sample changer and simplifying operations, the MA-3 Solo delivers exceptional performance in a compact and lightweight design. Its reduced installation requirements make it an ideal choice for users with lower sample throughput demand or those seeking for reliable secondary mercury analyzer that compliments what they already have in laboratory.

## MA-3 Solo Direct Mercury Analyzer

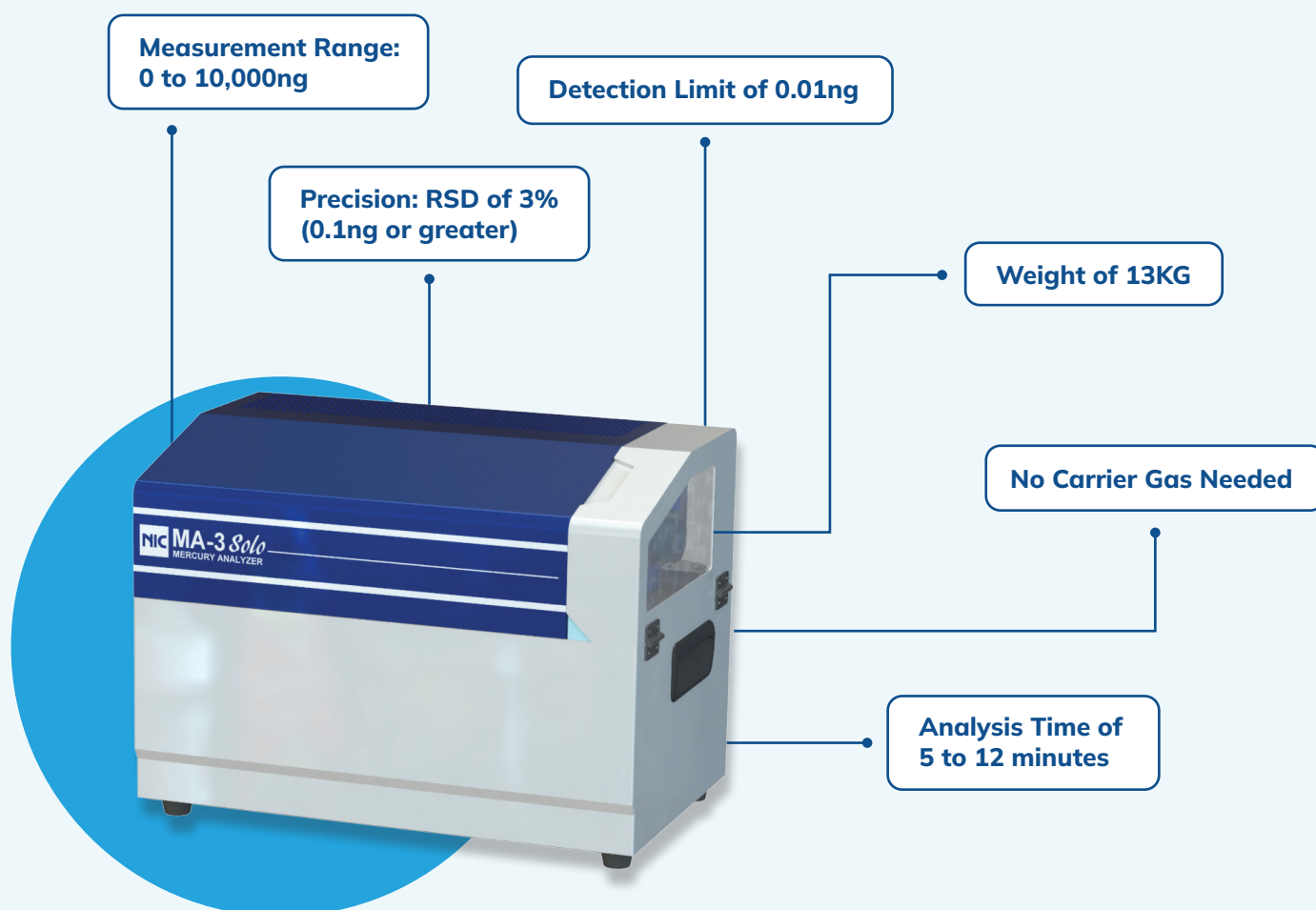

## Advantages Of Thermal Decomposition Analysis

Traditional acid-based sample decomposition method or acid digestion steps have been proven to be time consuming and might be even prone to errors. This conventional technique also might pose challenges, including complex sample preparation, risks of interference, potential loss of mercury during acid decomposition, and creating doubts at the end of the analysis. These methods demand expertise and careful monitoring, adding to the operational burden.

Direct thermal decomposition technique:

- Eliminates the need for time-consuming acid pre-treatment
- Enabling users—even those with minimal experience—to achieve accurate results with ease.
- This method is environmentally friendly, producing no acidic waste and aligning with every laboratory's goal to achieve sustainability.



# Method: Thermal Decomposition-Gold Amalgamation-Cold Vapor Atomic Absorption (TDA-CVAAS)

## Principle of Operation

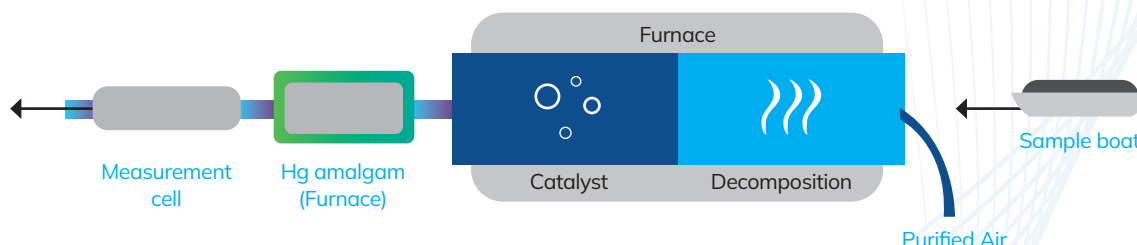

Schematic of thermal decomposition method

## Direct Thermal Decomposition

A weighed sample, placed in a ceramic sample boat, is placed into MA-3 Solo sample inlet. After selecting the right method for the sample, purified air begins to flow, and the decomposition furnace gradually increases its temperature in stages—first to dry the sample, then to decompose it. Temperature increases based on the selected method from the MA-3 Solo software. The resulting evolved gases are passed through a heated catalyst to convert all forms of mercury into elemental mercury, releasing free mercury vapor.

## Gold Amalgamation

The mercury vapor together with the combustion products are then swept into a gold amalgamation trap, where only mercury is concentrated while the waste gases will be diverted away from the detector and go into exhaust.

The trap is subsequently heated to release the purified mercury vapor, which is carried by a flow of purified room air into the measurement cell of an atomic absorption spectrometer for analysis.

## Cold Vapor Atomic Absorption Spectroscopy (CVAAS)

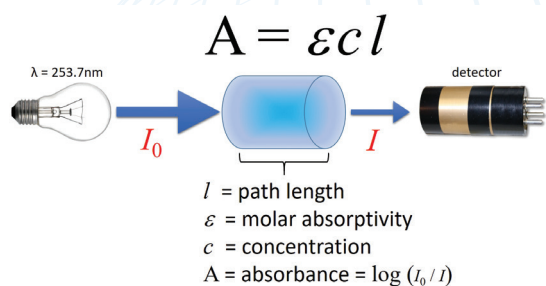

The NIC MA-3 Solo operates on the principle of cold vapor atomic absorption spectroscopy. In this method, monochromatic light at a wavelength of 253.7 nm passes through the measurement cell and is absorbed by mercury vapor. This process follows the Beer-Lambert Law, where absorbance is proportional to mercury concentration, assuming constant molar absorptivity and path length.

## MA-3 Solo Key Features & Benefits



### Affordable Robust Design with a Wide Measurement Range

Engineered for affordability, with easy-to-use manual boat loading and a sturdy “quick twist” load lock, the rugged MA-3 Solo is simple to operate and delivers a wide measurement range of 0 to 10,000ng with quick analysis time ranging from 5 to 12 minutes.

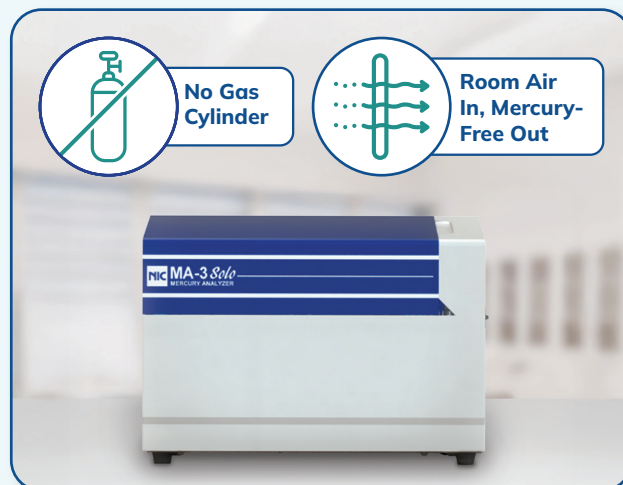

### Inexpensive Operation – No Gases or Consumables Required

MA-3 Solo was designed to be as simple to use as possible. Unlike other systems that require purified oxygen gas, purified room air is used as combustion and carrier gas. This design concept makes the instrument perfect for field portable operation or for use in mobile laboratories. The ceramic sample boats are easily cleaned for reuse. No gas requirement and reusable boats keep operating costs low.

### Advanced Optics for Superior Sensitivity and Stability

The MA-3 Solo utilizes a high-quality, thermally stabilized Hg-discharge lamp that emits a strong, stable emission at 253.7 nm, eliminating the need for intensity-reducing optical filters. Equipped with two robust semiconductor detectors for quantitative and reference measurements, the MA-3 Solo ensures reliable, long-lasting performance. Most of the other mercury analyzers uses inexpensive 50% transmittance mirrors to redirect light source, but this reduces the intensity and lowers the sensitivity.

MA-3 Solo employs high quality optical gratings. This advanced design directs the full intensity through the sample cell and to the reference detector, delivering superior sensitivity and unmatched stability.

# MA-3 Solo Key Features & Benefits

## Accurate & Precise Performance of MA-3 Solo

Equipped with Japanese best-in-class engineering design, robust hardware such as thermally-stabilized Hg-discharge lamp and robust semiconductor detector, MA-3 Solo provides **Reliability, Accuracy & Precision**. The data shown below illustrate the outstanding performance of MA-3 Solo in repeated measurement and accurate result from a Standard Reference Material.

Sample name	No. of Sample	Mean Value (ng)	CV (%)
Mercury Standard Solution of 0.05ng	5	0.050	4.6
Mercury Standard Solution of 0.1ng	5	0.099	2.9
Mercury Standard solution 100ng	5	101	0.4

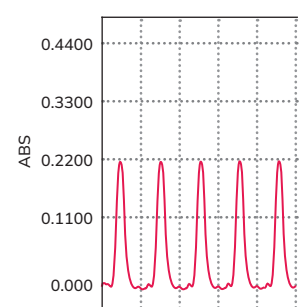
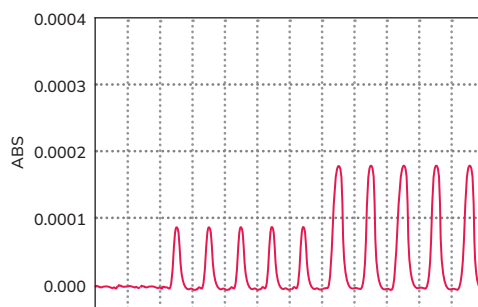

Sample name	Authentication range or measurement result	Measurement Result by MA-3 Solo			
		Amount of Sample	Number of Samples	Mean Value	CV (%)
Coal (NIST 1632d)	0.0895 – 0.0961mg/kg	50 – 57mg	5	0.0915mg/kg	2.1

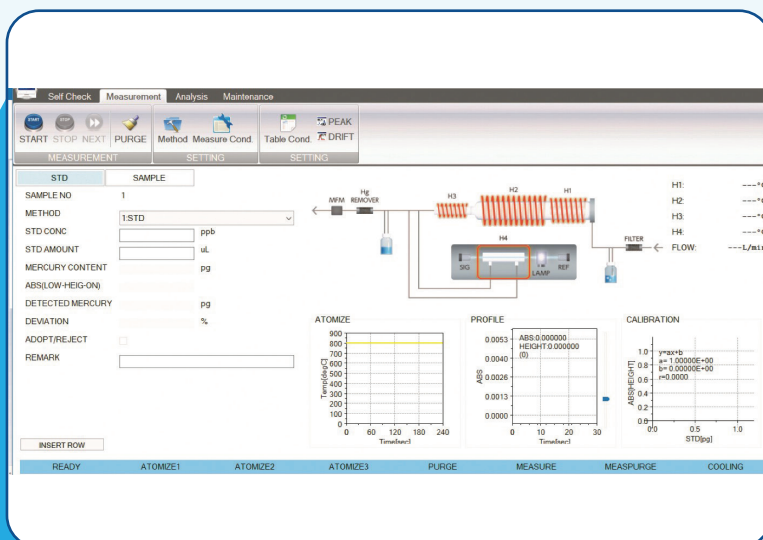

## Window Based and User-Friendly Graphical Software

MA-3Solo's software can be operated under both **Windows 10 Pro** and **Windows 11 Pro**. The software is intuitive to use and provides a real-time graphical representation of the measurement status.

## MA-3 Solo Key Features & Benefits

### Compact & Light Weight - Perfect Choice for On Site Measurement

Designed with mobility in mind, the MA-3 Solo features ergonomic handles and weighs only 13 kg (~28 lbs), making it lightweight and easy to transport.

The available carrying case ensures secure and convenient transportation for site projects or mobile laboratories. Its compact and portable design makes it an excellent choice for use in mobile environmental laboratories, enabling efficient studies of soil contamination in remediation, construction projects, mining exploration site or even offshore platforms.

It can run on any standard single-phase wall power, from 100-240 VAC (50/60Hz).

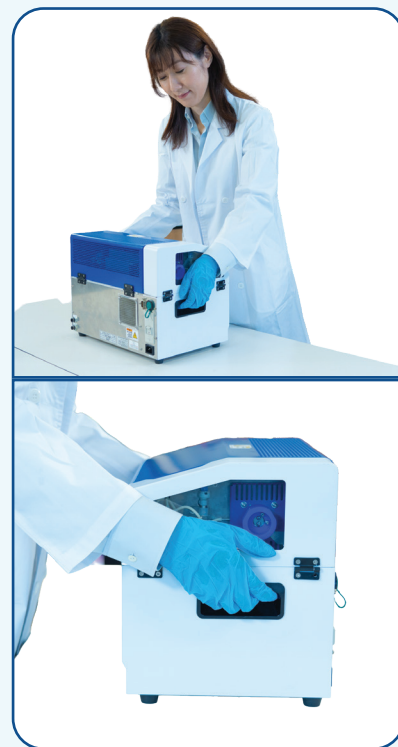

### Real Time Continuous Diagnostics

MA-3 Solo's software continuously monitors key diagnostics, such as all heater temps, flow rates, valve actuations, and voltages. This allows the software to automatically prompt the user if there is an issue, and it also allows for quick and easy troubleshooting for maximum uptime and reliability.

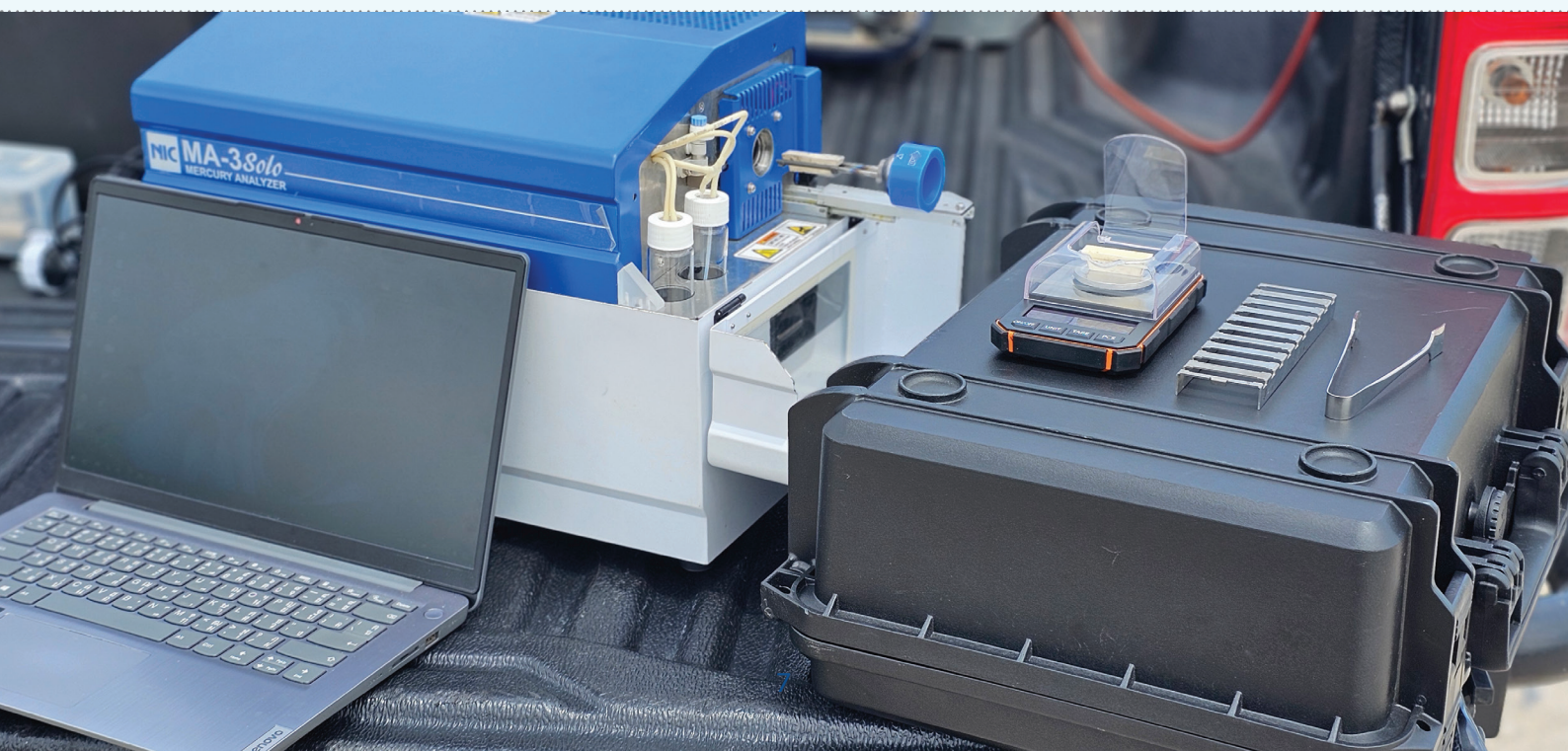

# MA-3 Solo Key Features & Benefits

## Superior Catalyst and Gold Amalgamator

With more than 40 years of know-how, MA-3 Solo's sample heating tube and mercury collector tube (gold trap) have such long lifetimes and superior designs that users never have to correct the calibration curve. Calibration curves generated for each catalyst maintain a consistent level of response throughout its lifespan, delivering reliable performance until the sample heating tube is replaced, typically after 9 to 12 months, depending on usage and application.



### Test Methods

USEPA 7473; ASTM D 6722-01; ASTM D 7623-10; UOP 1009-15; JIS K0102; UOP 938-20.

## Perfect Complementary Technique in Your Lab

For laboratories already equipped with other spectroscopic techniques like ICP-OES, ICP-MS, or CVAAS for mercury analysis, **the MA-3 Solo is the perfect complementary tool.**

Its Direct Thermal Decomposition technique is specifically designed to handle solid samples, non-aqueous liquids, and particulate-laden liquid matrices with unparalleled efficiency and ease. This method eliminates the need for complex and time-consuming sample preparation such as acid digestion or chemical reduction, resulting in a significantly faster turnaround time, saving you time and labour intensive requirements!



Any ICP-MS/ICP-OES

MA-3 Solo

Complementary Duo

Mercury's volatile nature makes its analysis tricky, as it increases the risk of contamination in trace elemental analysis systems, especially when dealing with high-concentration samples. The MA-3 Solo operates with minimal risk of cross-contamination, making it an ideal choice for high-concentration mercury analysis with minimal mercury memory effect and without compromising the condition integrity of other trace element analyzers in the laboratory.

By integrating the MA-3 Solo into their workflows, laboratories can achieve:

1. Streamlined workflows for challenging sample matrices like sludges, soils, oils, or particulate-laden liquids.
2. Enhanced productivity, as the MA-3 Solo provides rapid results, allowing laboratories to meet demanding deadlines.
3. Improved safety and precision, thanks to the fully enclosed system that minimizes exposure to mercury vapors and ensures reliable measurements.

The MA-3 Solo is a powerful addition that complements existing analytical setups, broadening the scope of mercury analysis while safeguarding laboratory instruments and ensuring compliance with stringent regulatory requirements.

### Best-In-Class Engineering

In summary, better optics, better components, and a better compact design are the hallmarks of all Nippon Instrument's direct combustion mercury analyzers dating back to the 1970s. Being dedicated to only mercury analysis makes NIC the first choice for your mercury analysis needs.

# MA-3 Solo – Designed for all types of Liquid Hydrocarbon Sample Matrices

The MA-3 Solo is specifically engineered to excel in the analysis of liquid hydrocarbon sample matrices, including condensate, naphtha, and crude oil. Certified for UOP938-20 compliance, it offers a reliable and efficient solution for determining total mercury and mercury species in these challenging sample types. By leveraging the Direct Thermal Decomposition technique, the MA-3 Solo eliminates the need for labor-intensive sample preparation for these group of samples that exhibit very distinct and different sample volatility, viscosity and characteristics, enabling faster and more precise analysis while reducing operational complexity.

## MA-3 Solo as a Complementary technique for users of PE-1000

For users of the NIC SP-3D, the MA-3 Solo stands out as an ideal replacement option. With its UOP938-20 compliance, it delivers reliable and high-precision results, ensuring a smooth transition and enhanced performance for mercury analysis.

Actual samples	Wastewater	11.6 mg/L <sup>1</sup>	200 µL	3	12.3 mg/L	3.7
	Crude Petroleum	3.75 mg/kg <sup>2</sup>	200 µL	5	3.88 mg/kg	2.4
	Naphtha	0.31 ug/kg <sup>3</sup>	200 µL	10	0.45 ug/kg	12.19
	Condensate	2.75 ug/kg <sup>3</sup>	200 µL	3	2.41 ug/kg	1.76
	Crude Petroleum	62.9 ug/kg <sup>3</sup>	90~125 mg	3	64.2 ug/kg	3.12
	Fuel Oil	395.2 ug/kg <sup>3</sup>	60~75 mg	3	396.8 ug/kg	0.12

<sup>1</sup> Measured by the reducing vaporization mercury analyzer RA-4500 (JIS K0102)

<sup>2</sup> Measured by the petro-pyrolysis mercury analyzer PE-1000 (UOP 938-10)

<sup>3</sup> Measured by the thermal decomposition mercury analyzer SP-3D (UOP 938-10)

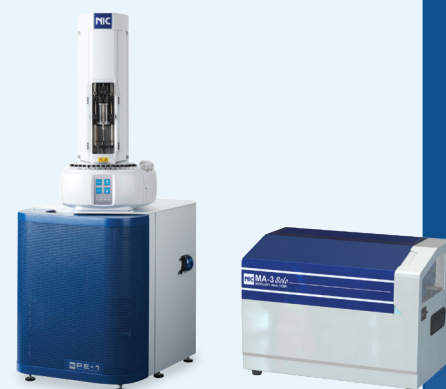

Other applications such as total mercury in condensate, naphtha and crude oil are available at our website [www.hg-nic.com](http://www.hg-nic.com).



NIC Application Note

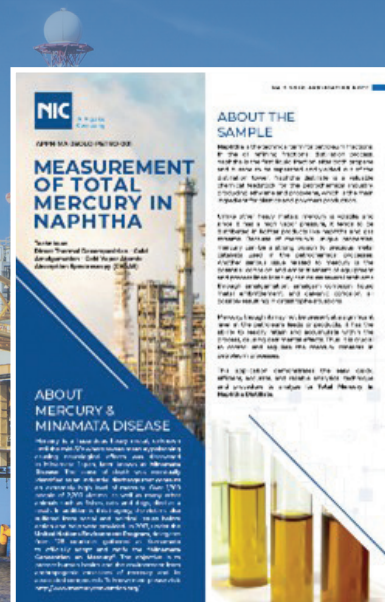

# MA-3 Solo Application

## Environmental

The MA-3 Solo is ideal for environmental monitoring applications, including the analysis of mercury in air, soil, sediment, and water samples. It supports regulatory compliance and research for pollution control, remediation projects, and environmental impact assessments.

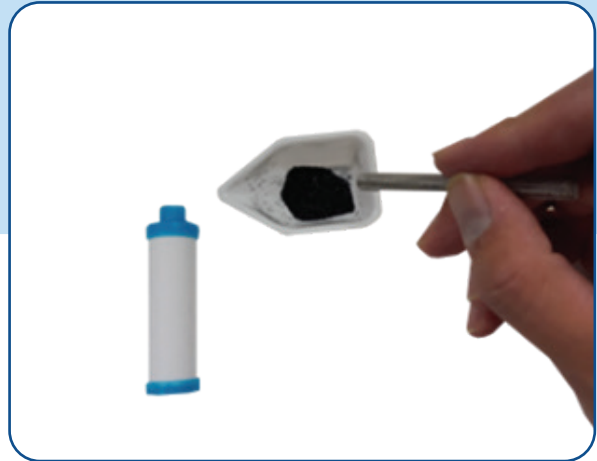

## Liquid Petroleum Matrices

Designed to meet the demands of the petroleum industry such as UOP938-20, the MA-3 Solo enables accurate mercury analysis in crude oil, natural gas, and refined products. It helps in ensuring product quality, safeguarding equipment, and adhering to industry standards.

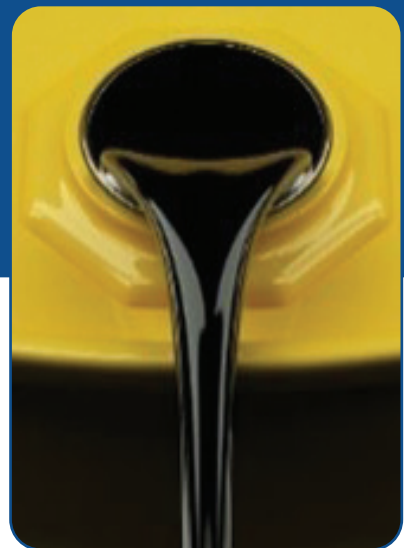

## Food & Agricultural Products

The MA-3 Solo ensures food safety and quality by measuring trace levels of mercury in food and agricultural products, such as grains, fish, and beverages. It supports compliance with international safety standards and enhances consumer protection.



## Biological Specimen

The MA-3 Solo offers precise analysis of mercury levels in biological specimens, including blood, urine, and tissue. It is essential for medical research, toxicology studies, and occupational health monitoring.

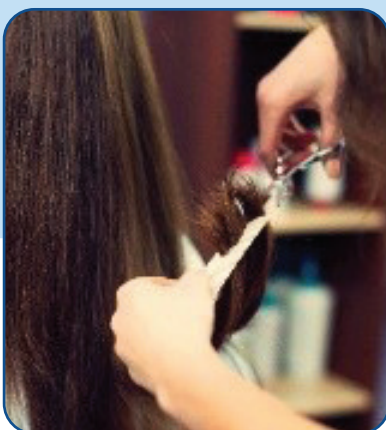

NIC Official Website

The versatility of the MA-3 Solo extends to a wide range of applications, including mercury analysis in chemical processes, industrial waste, and research materials. Its adaptability ensures reliable results across diverse industries and fields of study.

For other applications, please visit  
<https://www.hg-nic.com/application-data-centre/>

## Optional Attachments for MA-3 Solo – AQUA Kit

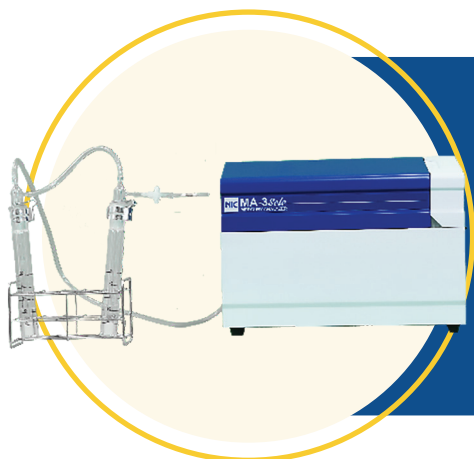

Aqueous samples like drinking water, spring water, oceans, rivers & lakes usually have relatively low levels of Mercury where it is a challenge to analyze by direct combustion analysis. For these applications, NIC has incorporated an optional attachment, called the AQUA Kit, to enable the MA-3 Solo to easily perform by reducing vaporization at low, sub-ppb detection limits.

### Principle of Operation (AQUA Kit)

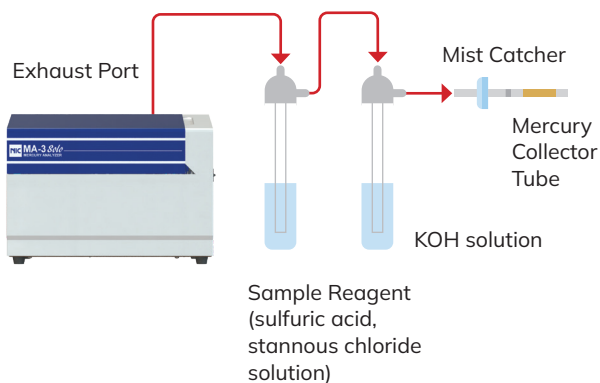

#### Specifications

Measurement Range	5ng/L - 50 µg/L (For measurement of 20ml)
Precision	RSD 3% (for 15ng/L or more)
Sample Volume	20ml
Dimension	464 x 366 x 176 (Carrying case)
Weight	6kg (including carrying case)

Note: To determine for Total Mercury by reducing vaporization, the aqueous samples have to be pre-acid-digested.

An impinger set is used in the AQUA Kit. Water samples are filled into the sample tube.  $\text{H}_2\text{SO}_4$  and  $\text{SnCl}_2$  to reduce all soluble  $\text{Hg}^{2+}$  in the water samples into  $\text{Hg}^0$



$\text{Hg}^0$  is then purged from the sample tube by using mercury free air from MA-3 Solo. The mercury vapor is trapped onto a Mercury Collector Tube. The Mercury Collector tube is loaded into MA-3 Solo. In MA-3 Solo, the Mercury Collector Tube will go through technique of direct thermal decomposition with gold amalgamation, followed by cold vapor atomic absorption spectroscopy (CVAAS) measurement.

By placing the Collector Tube in MA-3 Solo, the trapped mercury is released during the direct thermal decomposition stage and subsequently trapped on the MA-3 Solo's Gold Amalgamation Trap, isolating and concentrating the mercury. This trap is then heated to desorb the mercury into a carrier gas which transports it into the optical measurement cell of the CVAAS detector.

### Data Example #1

CALIBRATION

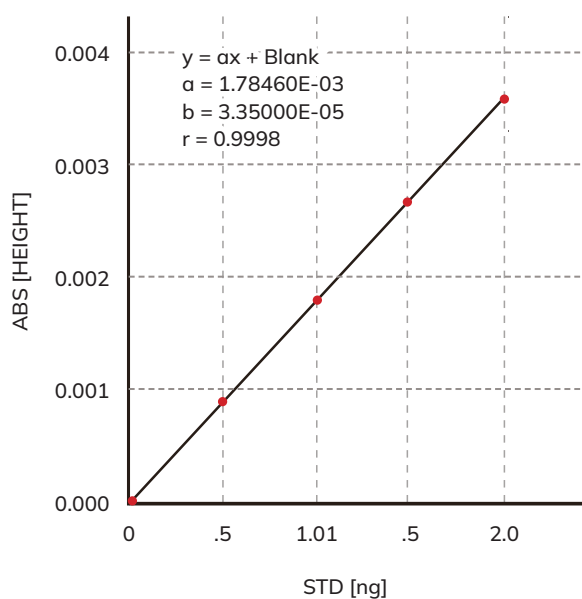

Calibration Data

STD [ppm]	SVOL [μL]	STD [ng]	LOW [Height]	MEAS [ng]	Dev. [%]
0.01	0	0	0.000036	0.001	-
0.01	50	0.5	0.000908	0.490	2.0
0.01	100	1.0	0.001626	1.004	0.4
0.01	150	1.5	0.002664	1.474	1.7
0.01	200	2.0	0.003638	2.020	1.0

Result

No.	Concentration	Trials	Ave [ppt]	SD [ppt]	C.V. [%]
1	50 ppt	5	48.89	0.81655	1.67
2	25 ppt	5	24.27	0.15652	0.64
3	10 ppt	5	9.88	0.38503	3.90
4	5 ppt	5	4.89	0.25836	5.28



## Optional Attachments for MA-3 Solo – Gas Analysis Kit



### Mercury in Ambient Air

Mercury can exist in the ambient air due to anthropogenic activities and natural events such as volcanic eruptions. Industrial activities to produce power such as stationary combustion of coal-fired power plants and other commodities with intentional use of mercury-added products in the process are some of many reasons for elemental mercury emissions due to anthropogenic activities. Since Gaseous Elemental mercury (GEM) is the least water-soluble form of mercury and thus it tends to stay longer in the atmosphere. Measuring GEM will be a good indication of mercury pollution in the air and the working environment.



### Mercury in Natural Gas

Geologically, mercury deposits naturally in the earth's crust, together with crude oil and natural gas wells. In the exploration and processing of these fossil fuels, if mercury is not being treated properly, it brings corrosion and eventually Liquid Metal Embrittlement (LME), leading to catastrophic accidents in the processing plants of the oil and gas industry. Thus, measuring elemental mercury is crucial and helpful to prevent such disastrous events from happening.

The main form of mercury in ambient air or LPG/LNG is primarily elemental mercury ( $\text{Hg}^0$ ) with a concentration ranging from few nanograms per cubic meter ( $\text{ng}/\text{m}^3$ ) to micrograms per cubic meter ( $\mu\text{g}/\text{m}^3$ ) depending on the location and source of emission.

To analyze elemental mercury with MA-3 Solo in all gaseous matrices, NIC has developed a Gas Analysis Kit, providing a solution for analysts with a single platform of MA-3 Solo without any hardware and software modification.



## Principle of Operation

### A Sampling Setup

#### Ambient Air

Gas Sampling Using Collector Tube

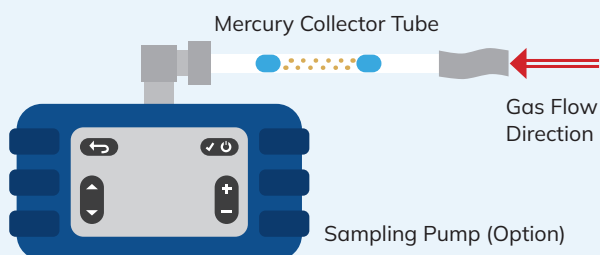

A Mercury Collector Tube (N65L) and a sampling pump are used to perform on-site air sampling. An external gas volume meter can be connected to measure on the total sampling volume. During gas sampling, elemental mercury will be trapped onto the mercury collector tube. The mercury collector tube is brought back to the laboratory for analysis by MA-3 Solo directly.

#### LPG/LNG

LPG/LNG Sampling Using LP-WA

For LPG/LNG and NG application, the sampling onto Mercury collector tube can be done in various ways, namely directly via Liquefied Gas Vaporizer sampling or *Tedlar Bag* sampling.

#### LPG/LNG Sampling Using Pressurized Sample Gas Cylinder

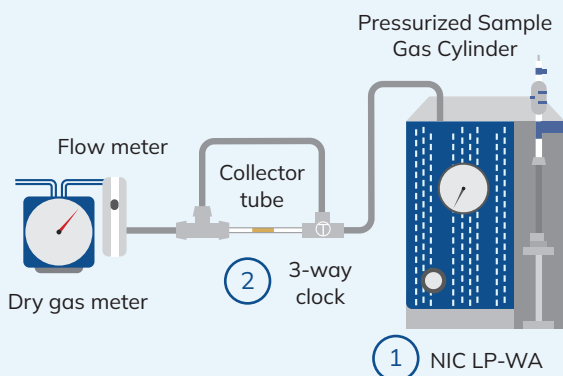

#### How it works:

1. With sample gas stored within the pressurized sampling cylinder, user can attach the cylinder onto the ① LP-WA Liquefied Gas Vaporizer.
2. The liquefied gas (e.g., propane or butane) stored within pressurized sample gas cylinder is vaporized gradually by the heated pressure reducing regulator to a constant flow of sample gas for sampling elemental mercury onto ② Mercury Collector Tube.
3. Elemental mercury in the gas is collected onto the mercury collector tube which is then sent to MA-3 Solo for measurement.

#### LPG/LNG Sampling Using Tedlar Bag

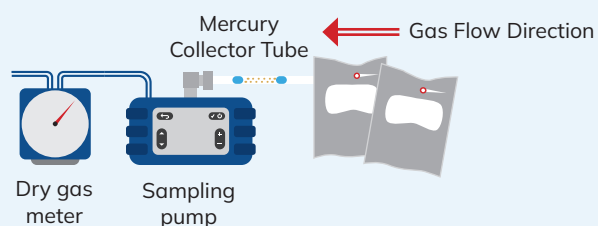

#### How it works:

1. For hydrocarbon gases collected in Tedlar bags, user can perform sampling of the gases onto mercury collector tube.
2. Since the gas is at atmospheric pressure within the Tedlar bag, a sampling pump is required to draw a constant flow of gas for elemental mercury sampling.
3. Elemental mercury in the gas is collected onto the mercury collector tube which is then sent to MA-3 Solo for measurement.

## B Measurement of Mercury Collector Tube

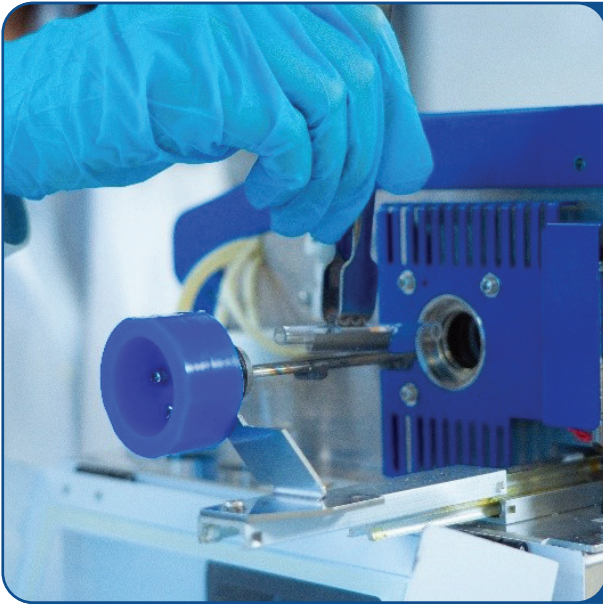

After sampling, the mercury collector tube can be loaded onto MA-3 Solo.

The thermal decomposition stage releases the Mercury from the collector tube and subsequently trapped onto MA-3 Solo's Gold Amalgamation Trap, re-concentrating and purifying the mercury. This trap is then heated to release the purified mercury into carrier gas which transports into optical cell of CVAAS detector for measurement.

All mercury collector tube can be reused after the measurement!

### Gas Analysis Kit Measurement Result:

#### Data #1 - Mercury Analysis of Propane gas with Standard Addition Test

Name	Trials	STD Add (ng)	Recovery (%)	SD (%)	C.V(%)
Propane	3	1.701ng	96.60	0.8888	0.92

#### Data #2 - Mercury Analysis of Ambient Air

In this measurement, Gaseous Elemental Mercury (GEM) in ambient air is being collected onto the mercury collector tube. The mercury collector tube is sent back to the laboratory to be measured by MA-3 Solo which then its measurement result is compared against AM-5 (NIC Mercury Continuous Mercury Monitor).

	MA-3 Solo (Gas Tube Analysis Kit)			AM-5 (Continuous Emission Monitoring System)
	Vol. (L)	Hg (ng)	Conc. (ng/m <sup>3</sup> )	Ave.(ng/m <sup>3</sup> )
11/16 11:25~14:03	69.5	0.169	2.43	2.75
11/16 14:05~17:41	93.2	0.224	2.40	2.63
11/17 8:00~11:00	61.8	0.161	2.61	2.42
11/18 11:25~14:14	82.6	0.201	2.43	2.41
11/18 14:14~15:54	50.3	0.109	2.17	2.32

Hg Concentration in AmbientAir\_Takatsuki City, Osaka

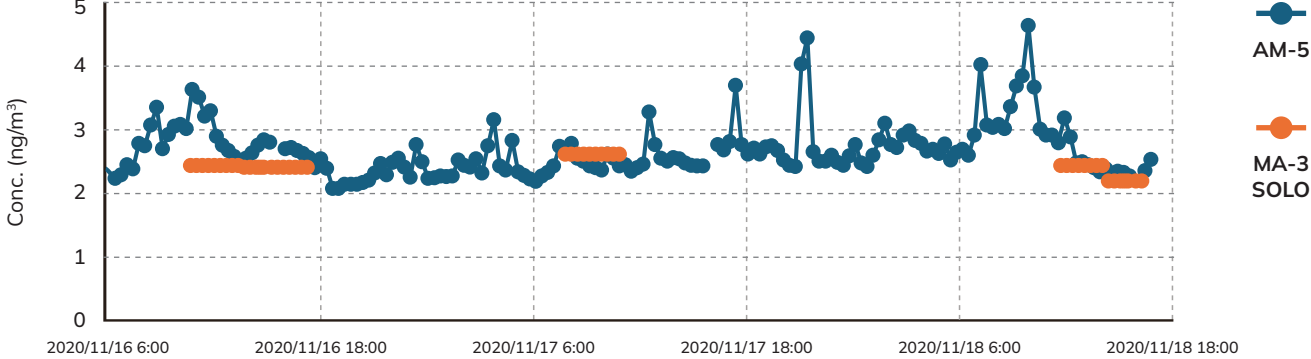

# Discover the MA Series

From high-throughput analysis to field-ready simplicity, NIC's MA Series offers a solution for every mercury measurement need. Whether you're looking for fully automated precision or compact portability, we've got you covered.

Visit our website [www.hg-nic.com](http://www.hg-nic.com) for more information.

Scan the QR  
Code to Visit Our  
Official Website



MA-3000 Mercury Analyzer

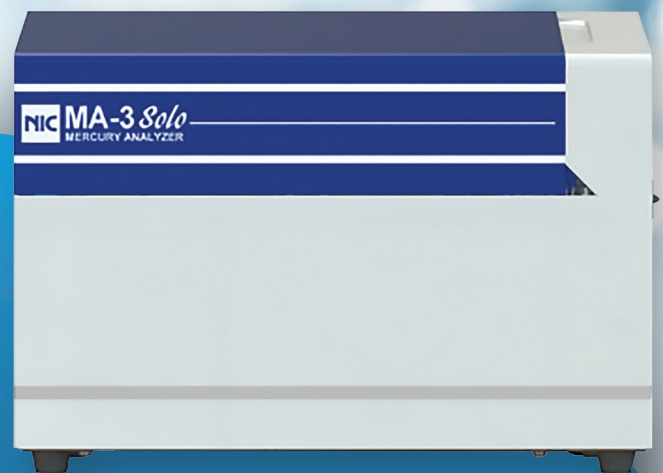

MA-3 Solo Mercury Analyzer



# NICares – Driving Sustainable Mercury Analysis

As part of our environmental responsibility initiative, NICares represents our commitment to sustainability in mercury analysis. Through thoughtful engineering, the MA-3 Solo helps laboratories operate more efficiently with minimal ecological impact.

## Why Sustainability Matters in Mercury Analysis

Mercury is a highly toxic element that poses serious risks to health and the environment. As a company dedicated to its detection and monitoring, we believe it's essential that our instruments do not contribute to the very problem they aim to solve. That's why our solutions are engineered to minimize waste, eliminate chemical use, and reduce environmental impact—ensuring responsible analysis for a safer world.



### Save Resources

The MA-3 Solo operates without chemicals, eliminating the need for sample reagents or gas cylinders—reducing both cost and environmental burden.

### Less Waste

By removing chemical preparation steps, no hazardous waste is generated during analysis, supporting clean and compliant laboratory operations.



### Save Energy

Designed with energy efficiency in mind, the MA-3 Solo minimizes gas emissions and power usage—ensuring environmentally conscious performance without compromising results.



Product images are for illustrative purposes only and may differ from the actual product



## Nippon Instruments Corporation

A Rigaku Company

**Osaka office /Tech. cent** : 110 Nishikujō Gawarajōchō, Minami Ward, Kyoto, 601-8424, Japan  
TEL: +81 75-748-6200 FAX: +81 75-748-6208  
E-MAIL: [info-nic@rigaku.co.jp](mailto:info-nic@rigaku.co.jp) URL: [www.hg-nic.com](http://www.hg-nic.com)  
**ISO 9001-2015 & ISO 14001:2015 Accredited**

**Singapore office** : 61 Bukit Batok Crescent  
#04-04A, Singapore 658078  
TEL: +65-6873-7068 FAX: +65-6873-6362

Distributors